

Triangular Omni Wheel Vectoring Robot Platform - IG32 DM

Assembly and Operation

Tri-wheel vectoring robot uses three omni wheels in a triangular pattern to move in any direction. Use this manual for TP-093-003 and TP-251-003.

Images shown may not be an exact representation of the robot's features listed in this document



Contents

Mechanical Assembly	3
Electrical Assembly	6
General Terms.....	6

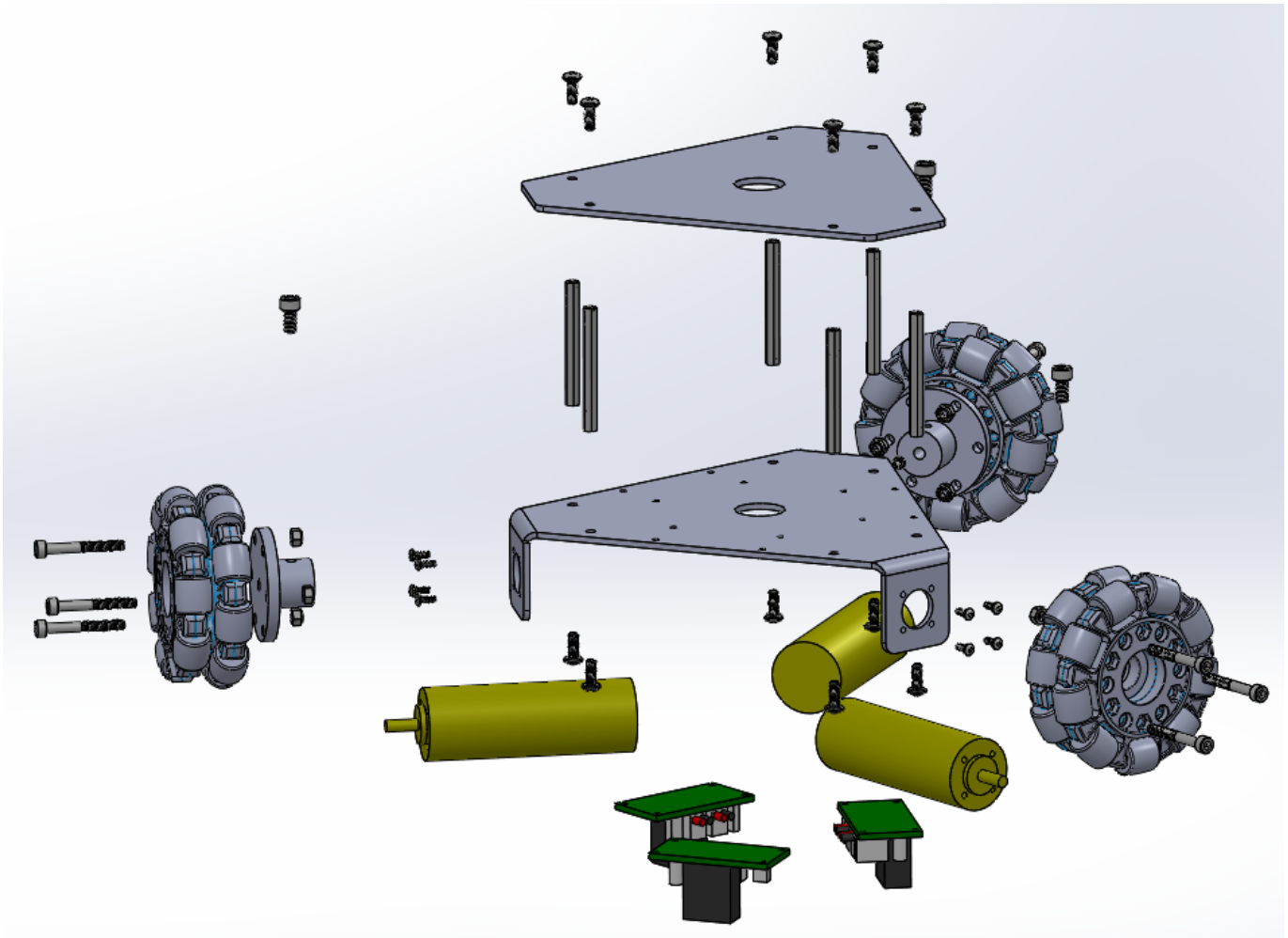

Exploded View Diagram

Mechanical Assembly

1. Mount the motors with the M3x8 screws provided.
2. Mount the omni wheels to the aluminum hubs by removing three of the screws in the wheel and replacing them with the longer screws and locknuts that are packaged with the wheel.
3. Slide the wheel/hub assembly onto the motor shaft and tighten the socket head screw in the hub down onto the flat part of the motor shaft. Make sure to catch the center of the flat or there will be a lot of backlash in the connection.

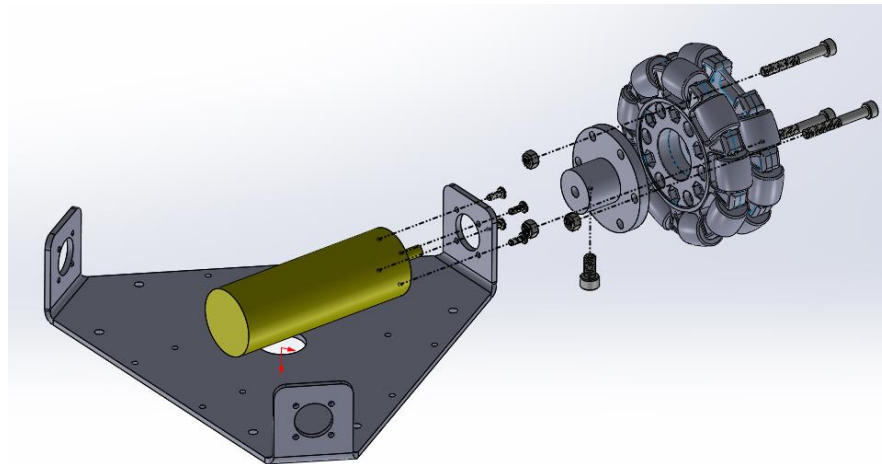

4. Mount the PWM motor controllers using the pre-drilled holes in the chassis. Use the plastic #4 spacers included in the hardware kit to stand the boards off from the chassis.

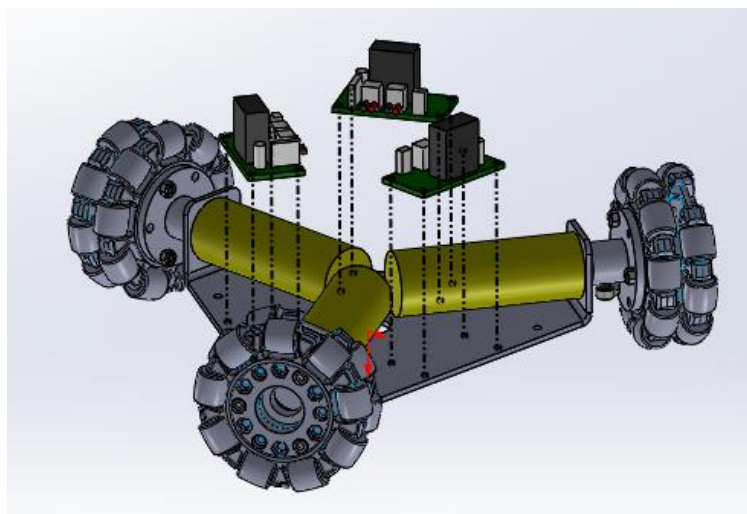

5. Attach the upper deck with the provided standoffs and screws.

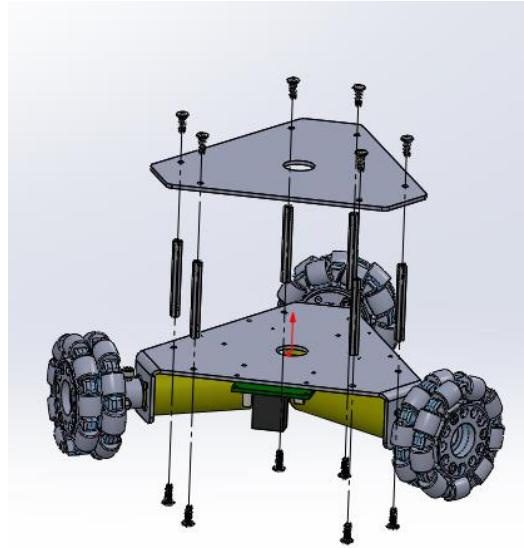

6. Layout where you want to mount the battery, switch, and other electronic components. The picture below has them mounted on the chassis. If you ordered an upper deck you can also mount them to the top or bottom of it depending on how you want to configure it. Mark the holes with a marker and drill them (use 1/8" bit for #4-40 clearance hole). Using a center punch before drilling helps prevent the drill bit from "walking" while drilling the hole.

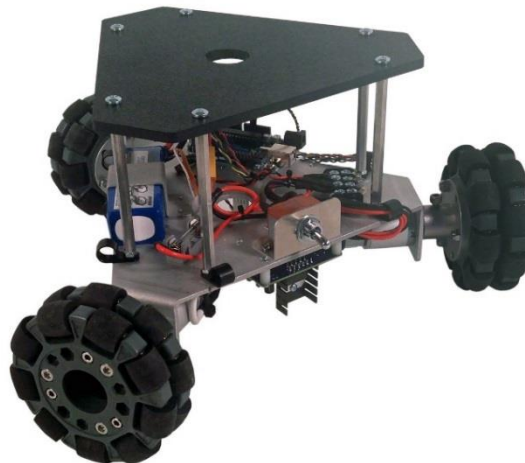



7. Once you have the electronic components mounted you are ready to proceed to the electrical assembly.

Electrical Assembly

For electrical assembly you can find the schematic on our website:

[Schematics](#)

For additional support on wiring, soldering, and crimping, please read the following support pages:

[Electric Motor Hookup Support](#)

[Electric Power Hookup Support](#)

[Soldering Tips](#)

[Crimping Wires](#)

General Terms

1. SuperDroid Robots, Inc is not responsible for special incidental or consequential damages resulting from any warranty or under any legal theory, including, but not limited to lost profits, downtime, goodwill, damage to, or replacement equipment or property, or any cost of recovering, reprogramming, or reproducing any data stored. ANY LIABILITY SHALL BE LIMITED TO REPLACEMENT OF DEFECTIVE PARTS. SuperDroid Robots, Inc. is further not responsible for any personal damages, including, but not limited to bodily and health damages resulting from any use of our products.
2. SuperDroid Robots, Inc. makes no representations as to the fitness of its products for specific uses. ANY IMPLIED WARRANTY OF MERCHANTABILITY OR FITNESS FOR A PARTICULAR PURPOSE IS HEREBY EXCLUDED.
3. Agreements shall be construed in accordance with the laws of the State of North Carolina, and the rights and obligations created hereby shall be governed by the laws of North Carolina.
4. In the event a dispute or controversy arises, such dispute or controversy (including claims of default) shall be brought in the courts of Wake County, North Carolina and the plaintiff hereby agrees to this choice of venue.