

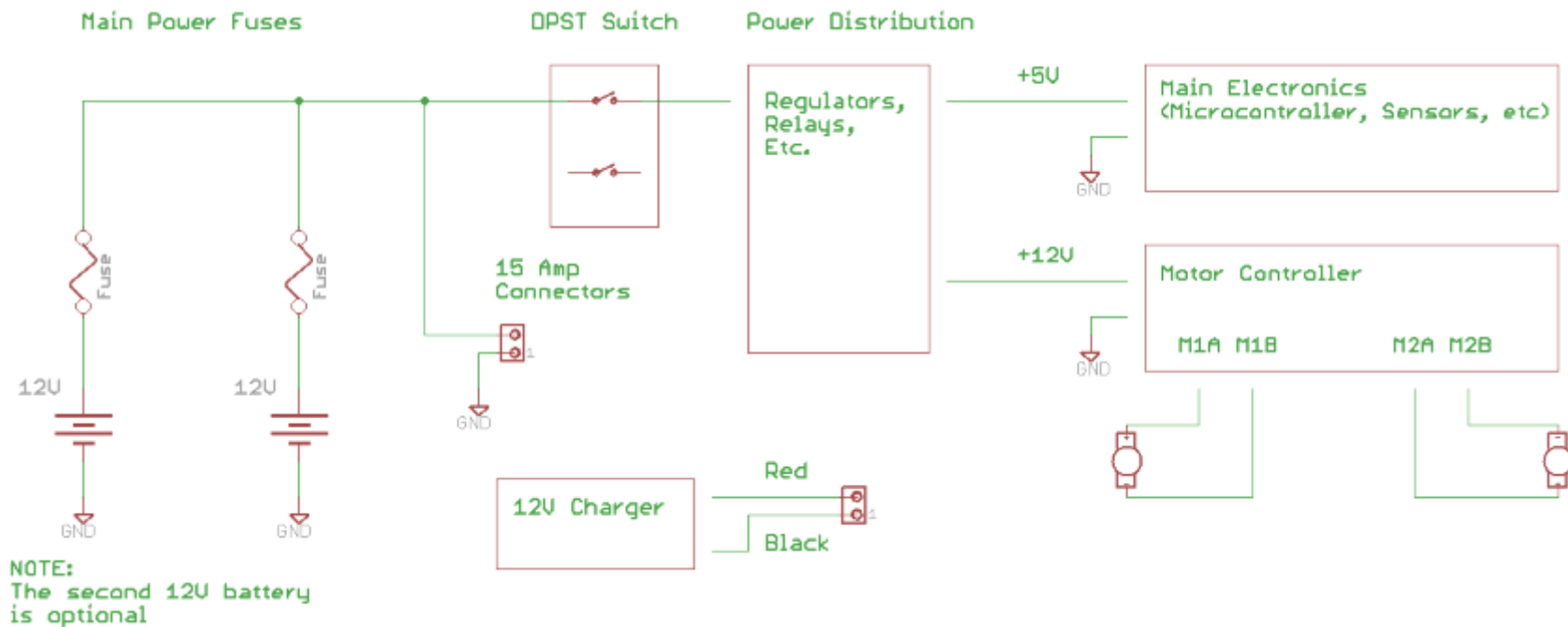

Typical ATR Power Hookup – 2WD Light Duty

© SuperDroid Robots
www.SuperDroidRobots.com



SAFETY NOTICE:

Be sure that all positive (red) battery terminals are properly fused and all wires are properly gauged according to safety standards.

Disclaimer:

Only qualified and experienced personnel should wire robots. SuperDroid Robots offers assembly of all their robot kits. Please see: <http://www.superdroidrobots.com/terms.htm>