

Notes:

- Its OK to connect ground to the chassis, however use wire to connect all ground terminations (same size as +V)
- Ensure all electronics are electrically isolated from chassis

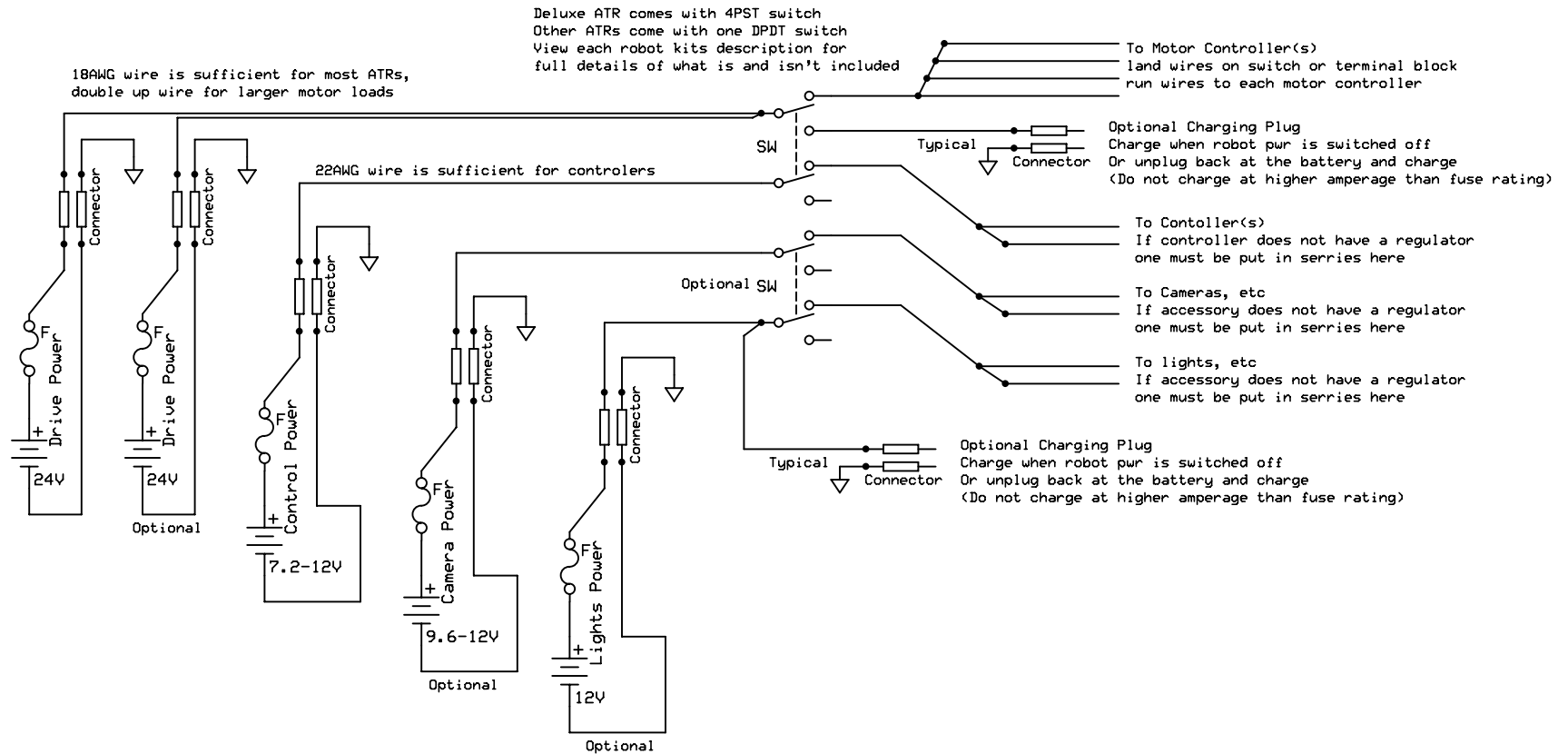

SuperDroid Robots Inc.

Typical ATR Power Schematic

Rev 2.0

12/16/2006

Page # 1 of 1