

Estimated Weight: 120lbs

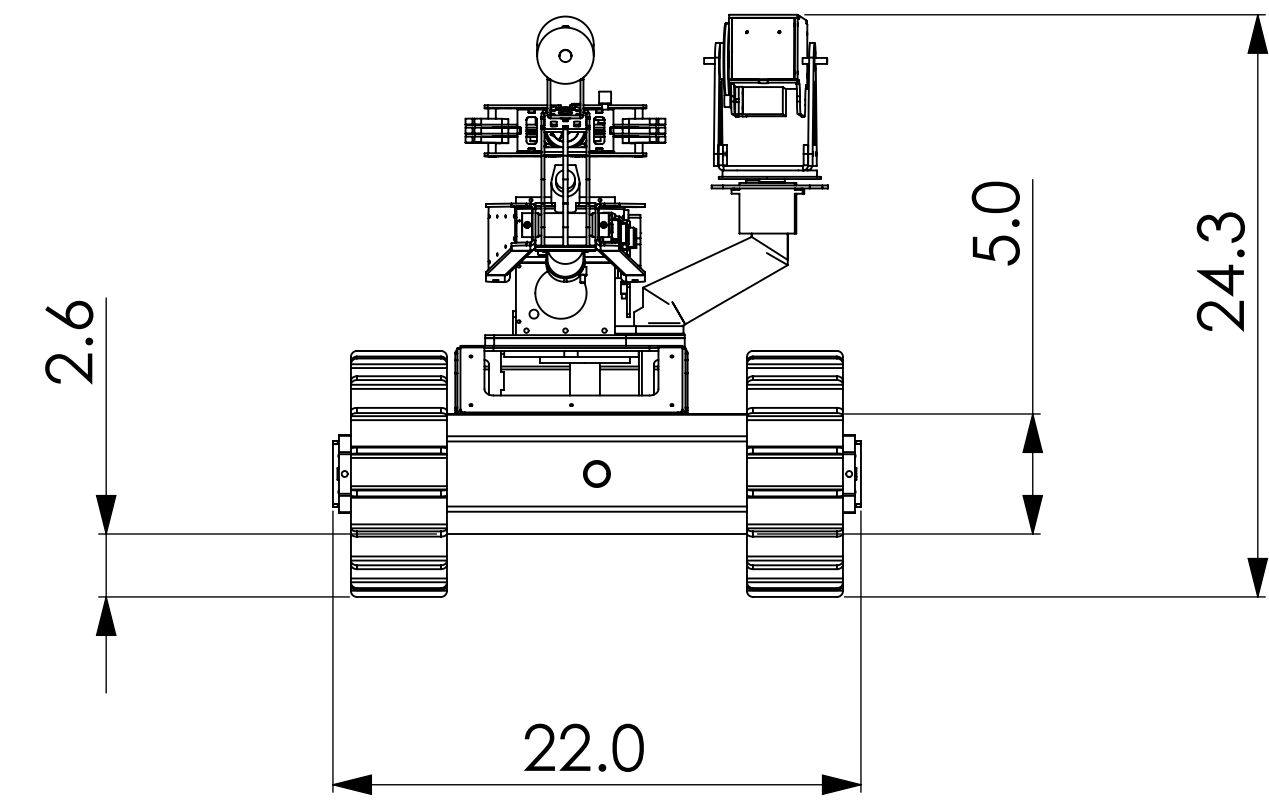
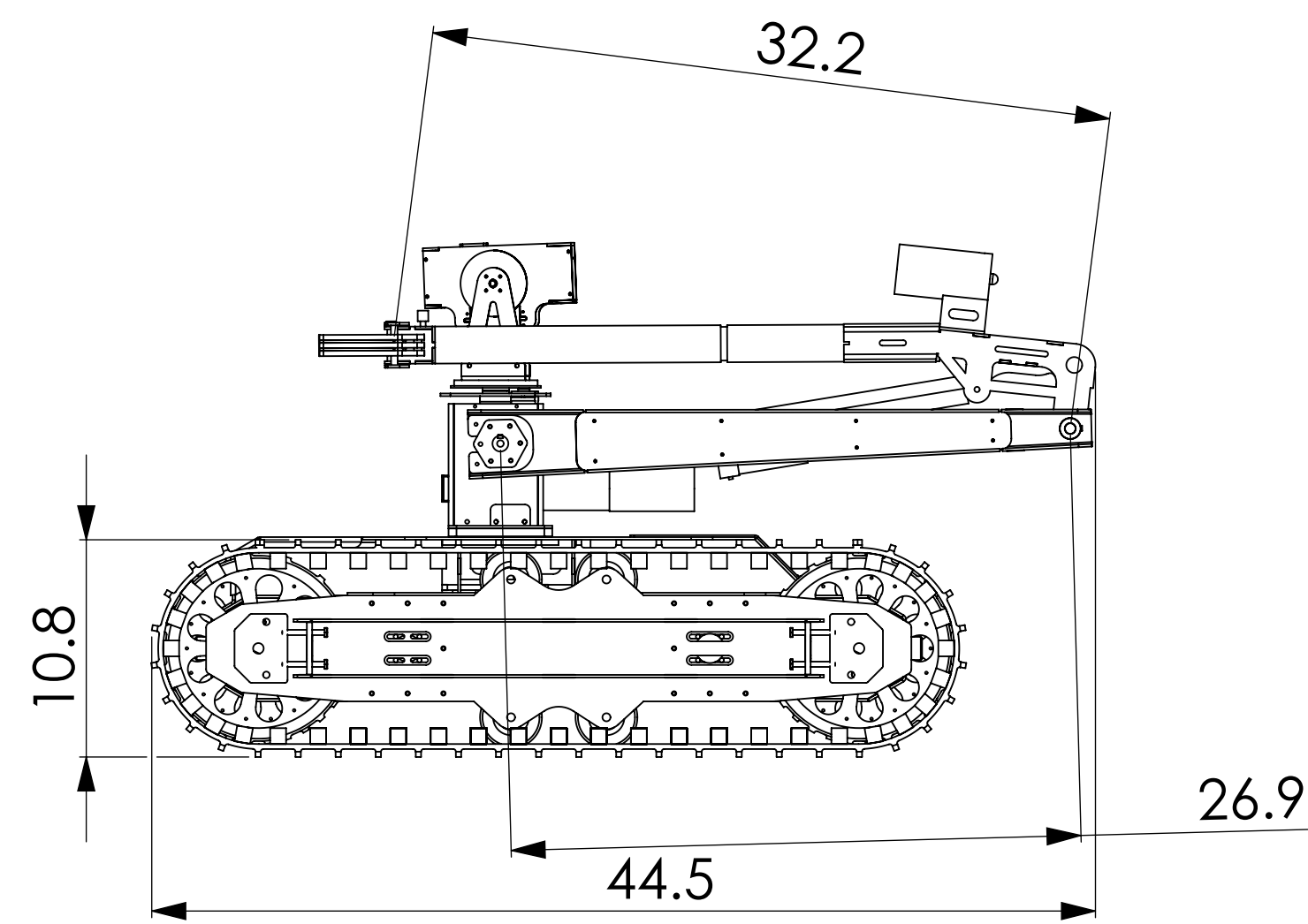
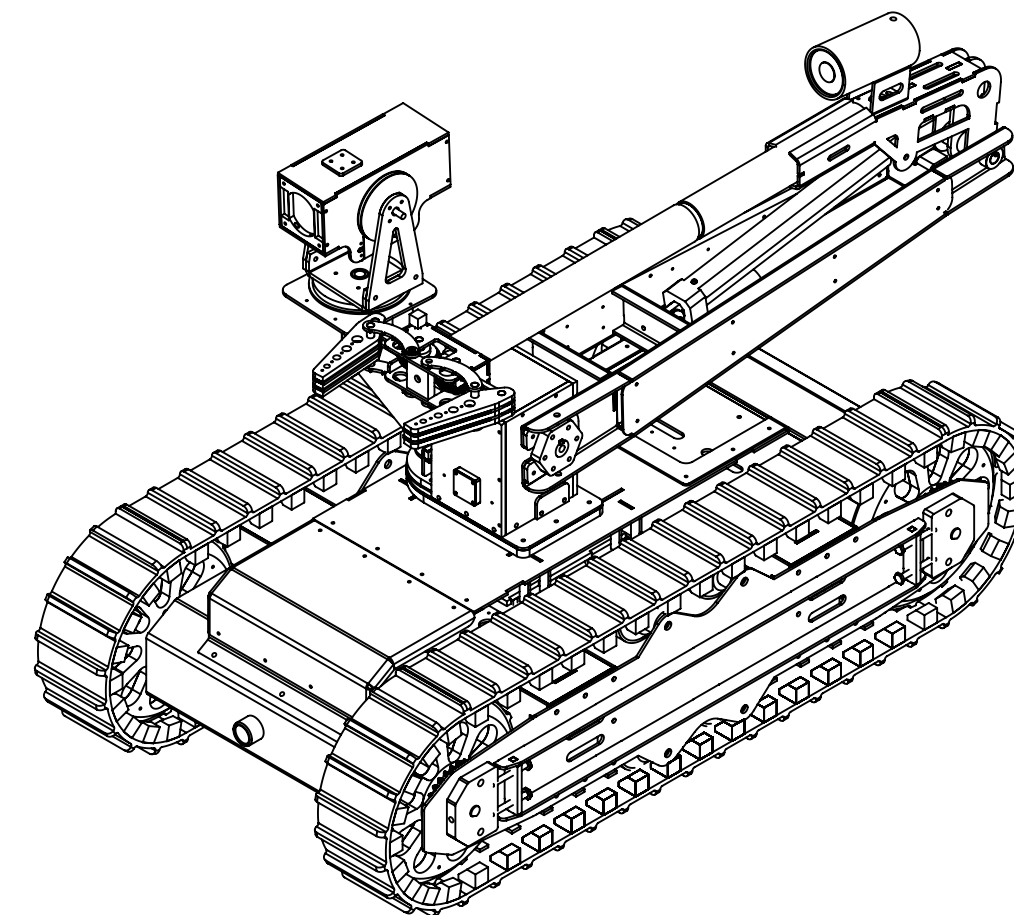
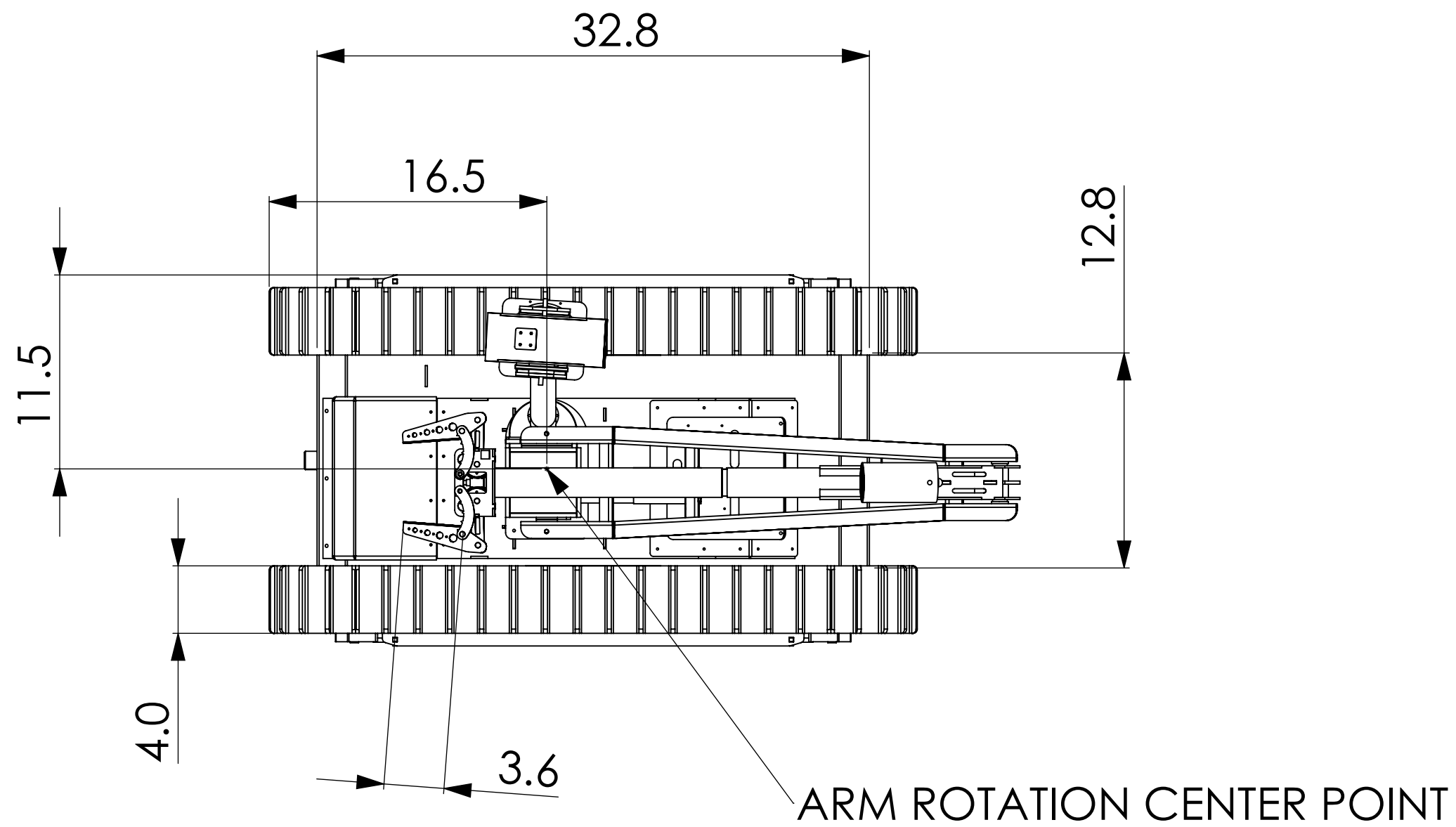

SUPERDROID ROBOTS INC
Ph: 919-557-9162
Fax: 775-416-2595

PROPRIETARY AND CONFIDENTIAL
THE INFORMATION CONTAINED IN THIS DRAWING IS THE SOLE PROPERTY OF SUPERDROID ROBOTS INC. ANY REPRODUCTION IN PART OR AS A WHOLE WITHOUT THE WRITTEN PERMISSION OF SUPERDROID ROBOTS INC IS PROHIBITED.

UNLESS OTHERWISE SPECIFIED:
DIMENSIONS ARE IN INCHES
ANGULAR: 0.5 deg
TWO PLACE DECIMAL ±0.03
THREE PLACE DECIMAL ±0.005

COMMENTS:

SIZE	DWG. NO.	REV
C	HD2+2W_5Axis	7-28-15
SCALE: 1:8	MATERIAL:	SHEET 1 OF 3

SHEET 1 OF 3