

**Notes:**

1. Assembly should be performed by knowledgeable and skilled individual. SuperDroid Robots offers assembly services if you are not comfortable reading schematics and performing work.
2. Wire gauges depend on load and size of motors.
3. Fuse size depends on load and size of motors.
4. Switch should be rated for at least the same amount of current as the fuse.
5. To charge batteries unplug them and use charger or run parallel wire with plug for charger.
6. Servo pigtail (TE-040-001) typically used. Receiver powered from motor controller (ensure motor controller rated for receiver).

**RC receiver Pin out**

1	2	3
4	5	6
7	8	9
10	11	12

RC Receiver  
 Note In receiver connect:  
 1. 0 v to pin 3, 6, 9 or 12.  
 2. 5V to pin 2, 5, 8 or 11.

**Arduino Pin Out**

6	(Tx)S1
7	(Estop)S2
11	StrafeRC
12	DriveRC
13	TurnRC
46	(Front)S1
47	(Front)S2
48	(Rear)S1
49	(Rear)S2
50	MISO
51	MOSI
52	SCK
5V	
GND	

Dual Encoder Breakout Board

Sabertooth Front  
 Address 128  
 Dip Switches 3, 4, 5, 6 ON

Sabertooth Rear  
 Address 129  
 Dip Switches 3, 5, 6 ON



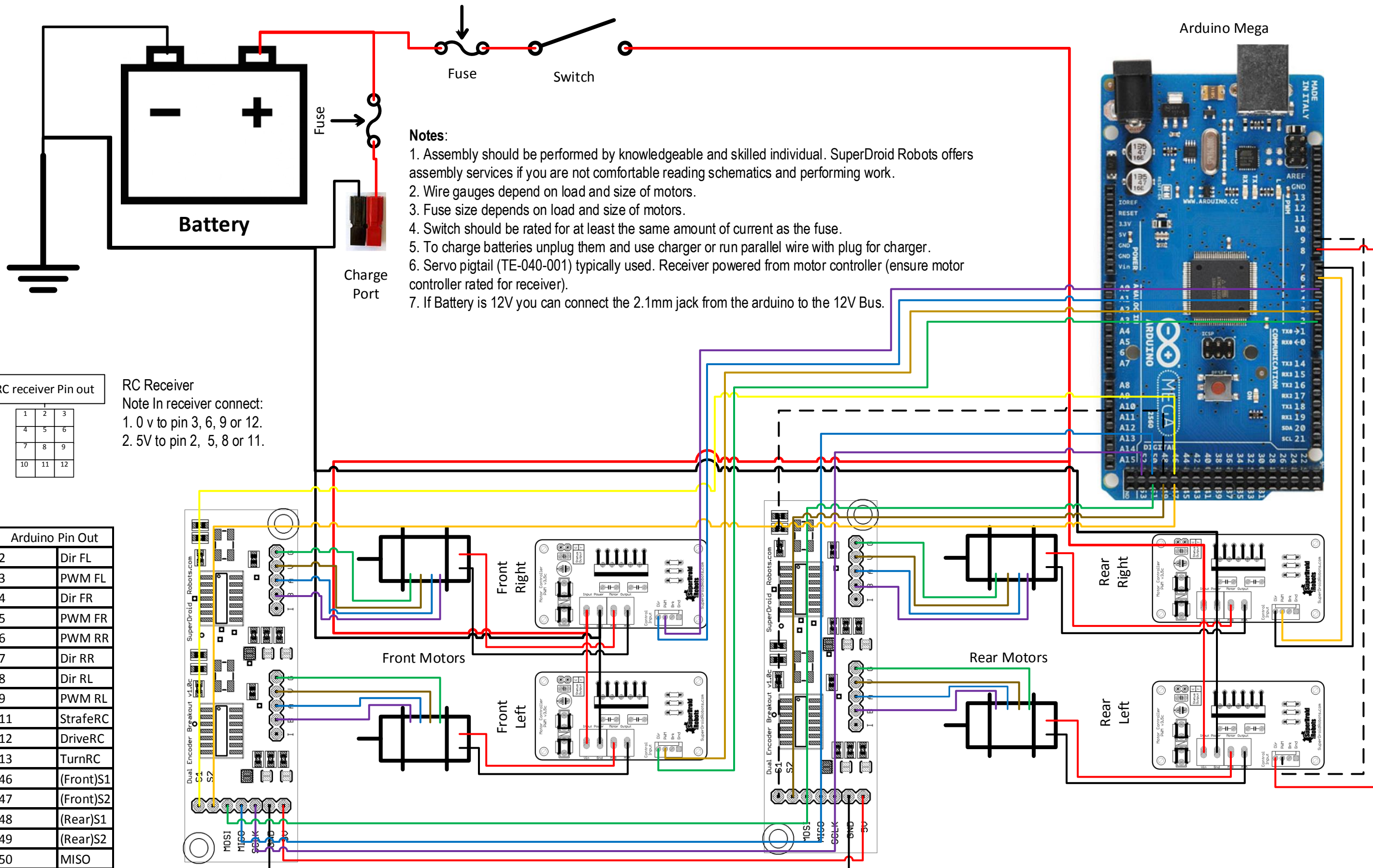

- Notes:**
1. Assembly should be performed by knowledgeable and skilled individual. SuperDroid Robots offers assembly services if you are not comfortable reading schematics and performing work.
  2. Wire gauges depend on load and size of motors.
  3. Fuse size depends on load and size of motors.
  4. Switch should be rated for at least the same amount of current as the fuse.
  5. To charge batteries unplug them and use charger or run parallel wire with plug for charger.
  6. Servo pigtail (TE-040-001) typically used. Receiver powered from motor controller (ensure motor controller rated for receiver).
  7. If Battery is 12V you can connect the 2.1mm jack from the arduino to the 12V Bus.

**RC receiver Pin out**

1	2	3
4	5	6
7	8	9
10	11	12

RC Receiver  
 Note In receiver connect:  
 1. 0 v to pin 3, 6, 9 or 12.  
 2. 5V to pin 2, 5, 8 or 11.

**Arduino Pin Out**

2	Dir FL
3	PWM FL
4	Dir FR
5	PWM FR
6	PWM RR
7	Dir RR
8	Dir RL
9	PWM RL
11	StrafeRC
12	DriveRC
13	TurnRC
46	(Front)S1
47	(Front)S2
48	(Rear)S1
49	(Rear)S2
50	MISO
51	MOSI
52	SCK

Dual Encoder Breakout Board

