

Description

The MA3 is a miniature rotary absolute shaft encoder that reports the shaft position over 360 ° with no stops or gaps. The MA3 is available with an analog or a pulse width modulated (PWM) digital output.

Analog output provides an analog voltage that is proportional to the absolute shaft position. Analog output is only available in 10-bit resolution.

PWM output provides a pulse width duty cycle that is proportional to the absolute shaft position. PWM output is available in 10-bit and 12-bit resolutions. While the accuracy is the same for both encoders, the 12-bit version provides higher resolution.

Three shaft torque versions are available. The standard torque version has a sleeve bushing lubricated with a viscous motion control gel to provide torque and feel that is ideal for front panel human interface applications.

The no torque added option has a sleeve bushing and a low viscosity lubricant (that does not intentionally add torque) for low RPM applications where a small amount of torque is acceptable.

The ball bearing version uses miniature precision ball bearings that are suitable for high speed and ultra low torque applications. The shaft diameter for ball bearing version option is 1/8" rather than 1/4".

Connecting to the MA3 is simple. The 3-pin high retention snap-in 1.25mm pitch polarized connector provides for +5V, output, and ground.



Features

- ▶ Miniature size (0.48" diameter)
- ▶ Non-contacting magnetic single chip sensing technology
- ▶ -40C to 125C operating temperature range
- ▶ 10-bit Analog output - 2.6 kHz sampling rate
- ▶ 10-bit PWM output - 1024 positions per revolution, 1 kHz
- ▶ 12-bit PWM output - 4096 positions per revolution, 250 Hz

Mechanical Drawing

 **Environmental**

Parameter	Value
Operating Temperature	-40C to +125C
Humidity, Non-condensing	5% to 85%
Vibration (5Hz to 2kHz)	20 G.
Electrostatic Discharge, Human Body Model MIL-STD-883E, Method 3015.7	± 2 kV

 **Mechanical**

Specification	Sleeve Bushing	Ball Bearing
Moment of Inertia	4.1 x 10 ⁻⁶ oz-in-s ²	4.1 x 10 ⁻⁶ oz-in-s ²
Max. Shaft Speed (1)	100 rpm	15000 rpm
Max. Acceleration	10000 rad/sec ²	250000 rad/sec ²
Max. Shaft Torque	0.5 ± 0.2 in-oz (D - torque option) 0.3 in-oz (N- torque option)	0.05 in-oz
Max. Shaft Loading	2 lb. dynamic 20 lb. static	1 lb.

Specification	Sleeve Bushing	Ball Bearing
Bearing Life (2)	> 1,000,000 revolutions	$L_{10} = (18.3/F_r)^3$ Where L_{10} = bearing life in millions of revs, and F_r = radial shaft loading in pounds
Weight	0.46 oz.	0.37 oz.
Max. Shaft Total Indicated Runout	0.0015 in.	0.0015 in.
Technical Bulletin TB1001 - Shaft and Bore Tolerances		Download

(1) When a pulley, gear, or friction wheel drives the shaft, the Ball Bearing option is recommended instead of the Sleeve Bushing. The chip that decodes position uses sampled data. There will be fewer readings per revolution as the speed increases. The formula for number of readings per revolution is given by:

10-bit PWM:

$$n = 625200 / \text{rpm}$$

12-bit PWM / Analog:

$$n = 156600 / \text{rpm}$$

(2) only valid with negligible axial shaft loading

Mounting

Parameter	Value
Hole Diameter	0.375" +0.005 / -0.0
Panel Thickness	0.125" max.
Panel Nut Max. Torque	20 in.-lbs.

Materials

Component	Material	Torque Option(s)
Shaft	Stainless	Sleeve Bushing (-D and -N options)
	Brass	Ball Bearing (-B option only)
Bushing	Brass	-

Magnetic Field Crosstalk

The MA3 absolute encoder contains a small internal magnet, mounted on the end of the shaft that generates a weak magnetic field extending outside the housing of each encoder. If two MA3 units are to be installed closer than 1 inch apart (measured between the center of both shafts), a magnetic shield, such as a small steel plate should be installed in between to prevent one encoder from causing small changes in reported position through magnetic field cross-talk.

Electrical

Parameter	Min.	Typ.	Max.	Units
Power Supply	4.5	5.0	5.5	Volts
Supply Current	-	16	20	mA
Power-up Time	-	-	50	mS

Analog Output Operation

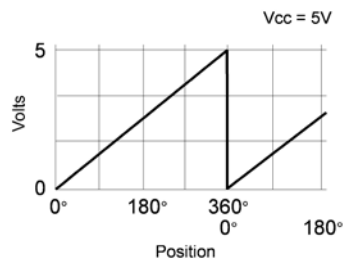

Analog output is only available in 10-bit resolution. The analog output voltage is ratiometric to the power supply voltage and will typically swing within 15 millivolts of the power supply rails with no output load. This non-linearity near the rails increases with increasing output loads. For this reason, the output load impedance should be $\geq 4.7k\Omega$ and less than 100pF. The graphs below show the typical output levels for various output loads when powered by a 5V supply.

Parameter	Min.	Typ.	Max.	Units
Position Sampling Rate	2.35	2.61	2.87	kHz
Propagation Delay	-	-	384	?S
Analog Output Voltage Maximum (1)	-	4.987	-	Volts
Analog Output Voltage Minimum (1)	-	0.015	-	Volts
Output Short Circuit Sink Current (2)	-	32	50	mA
Output Short Circuit Source Current (2)	-	36	66	mA
Output Noise (2)	160	220	490	μ Vrms
Output Transition Noise (3)	-	0.03	-	Deg. RMS

- (1) With no output load. See graphs below.
- (2) Continuous short to +5V or ground will not damage the MA3.
- (3) Transition noise is the jitter in the transition between two adjacent position steps.

Output Voltage vs. Output Load w/ Pullup Resistors to +5V

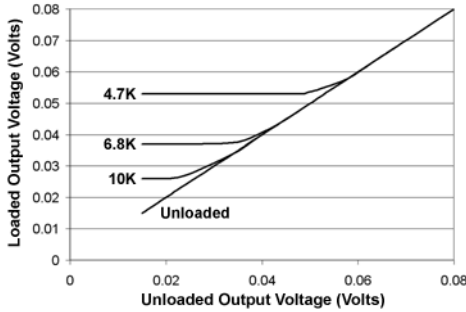

Output Voltage vs. Output Load w/ Pulldown Resistors to GND

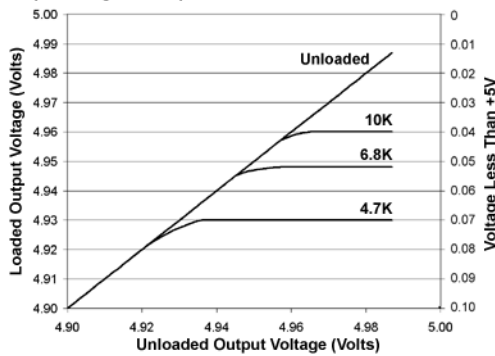

PWM Output Operation

The magnetic sensor chip in the MA3 has an on-chip RC oscillator which is factory trimmed to 5% accuracy at room temperature (10% over full temperature range). This tolerance influences the sampling rate and pulse period of the PWM output. If only the PWM pulse width t_{on} and the nominal pulse period is used to measure the angle, the resulting value also has this timing tolerance. However, this tolerance can be cancelled by measuring both t_{on} and t_{off} and calculating the angle from the duty cycle.

Parameter	Min.	Typ.	Max.	Units
PWM Frequency (-40C to 125C)				
10-bit	0.877	0.975	1.072	kHz
12-bit	220	244	268	Hz
Minimum Pulse Width				
10-bit	0.95	1.00	1.05	?S
12-bit	0.95	1.00	1.05	?S
Maximum Pulse Width				
10-bit	974	1025	1076	?S
12-bit	3892	4097	4302	?S
Internal Sampling Rate				
10-bit	9.38	10.42	11.46	kHz
12-bit	2.35	2.61	2.87	kHz

Parameter	Min.	Typ.	Max.	Units
Propagation				
10-bit	-	-	48	?S
12-bit	-	-	384	?S
Output Transition Noise, 12-bit version (1)		0.03		Deg. RMS
Output Transition Noise, 10-bit version (1)		0.12		Deg. RMS
Output High Voltage (V OH: @4mA Source) (2)	Vcc -0.5	-	-	V
Output Low Voltage (V OL: @4mA Sink) (2)	-	-	0.4	V

(1) Transition noise is the jitter in the transition between two adjacent position steps.

(2) Continuous short to +5V or ground will not damage the MA3.

10-bit PWM:

$$x = ((t_{on} * 1026) / (t_{on} + t_{off})) - 1$$

If $x \leq 1022$, then Position = x

If $x = 1024$, then Position = 1023

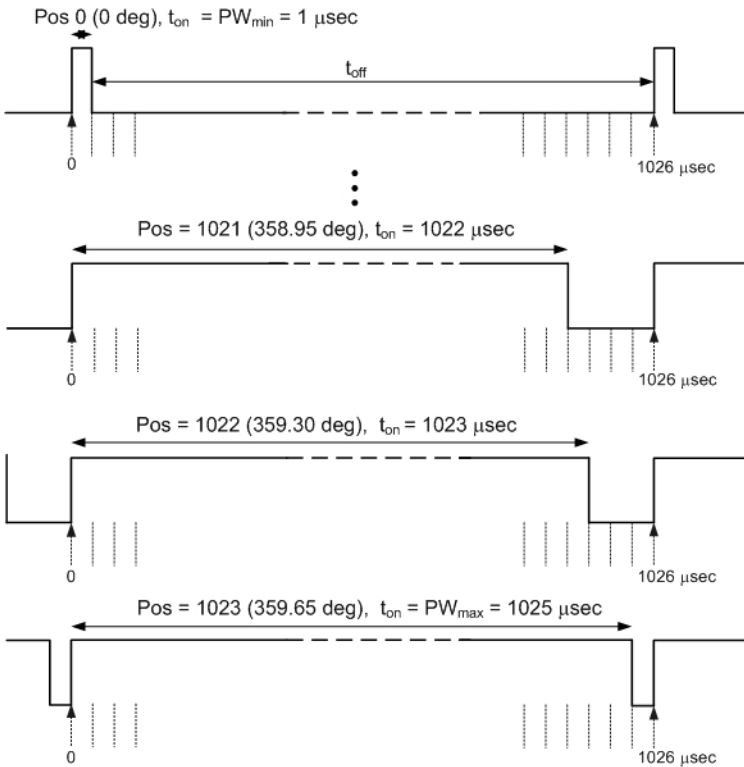

12-bit PWM:

$$x = ((t_{on} * 4098) / (t_{on} + t_{off})) - 1$$

If $x \leq 4094$, then Position = x

If $x = 4096$, then Position = 4095

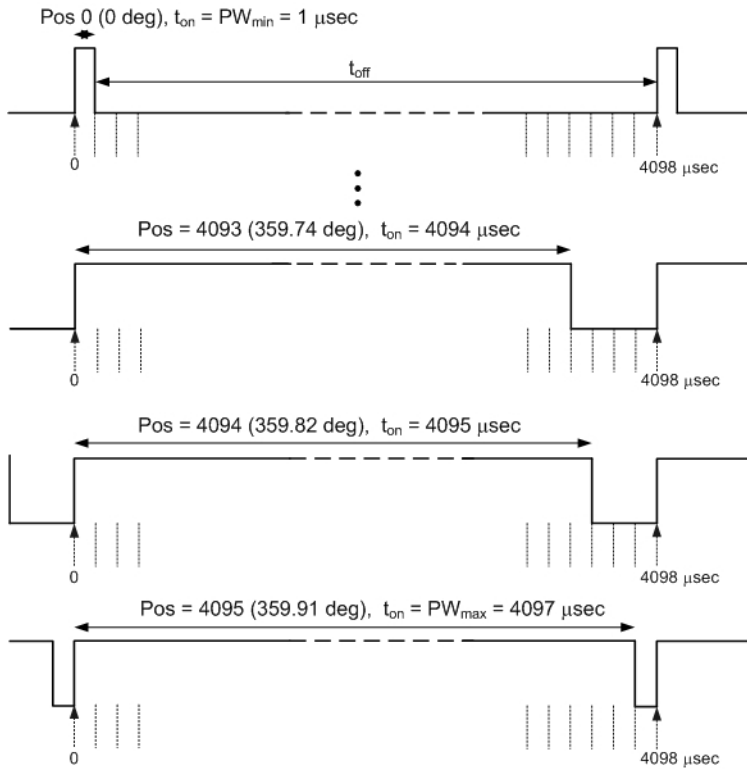

 Pin-outs

Analog Output (MA3-A):

Pin	Name	Description
1	5	+5VDC power
2	A	Analog output
3	G	Ground

PWM Output (MA3-P10, MA3-P12):

Pin	Name	Description
-----	------	-------------

1	5	+5VDC power
2	A	PWM output
3	G	Ground

Ordering Information

MA3 - - -

Interface

A10 = 10-Bit
Analog

P10 = 10-Bit
PWM

P12 = 12-Bit
PWM

Shaft Diameter

125 = 1/8"

236 = 6mm

250 = 1/4"

Torque

D = Sleeve Bushing,
Most Drag

N = Sleeve Bushing,
Somewhat Lighter Drag

B = Ball Bearing, Free
Spinning (Least Drag)

Notes

- Cables and connectors are not included and must be ordered separately.
- US Digital warrants its products against defects in materials and workmanship for two years. See complete warranty for details.