

ONLY USED WITH TETHER

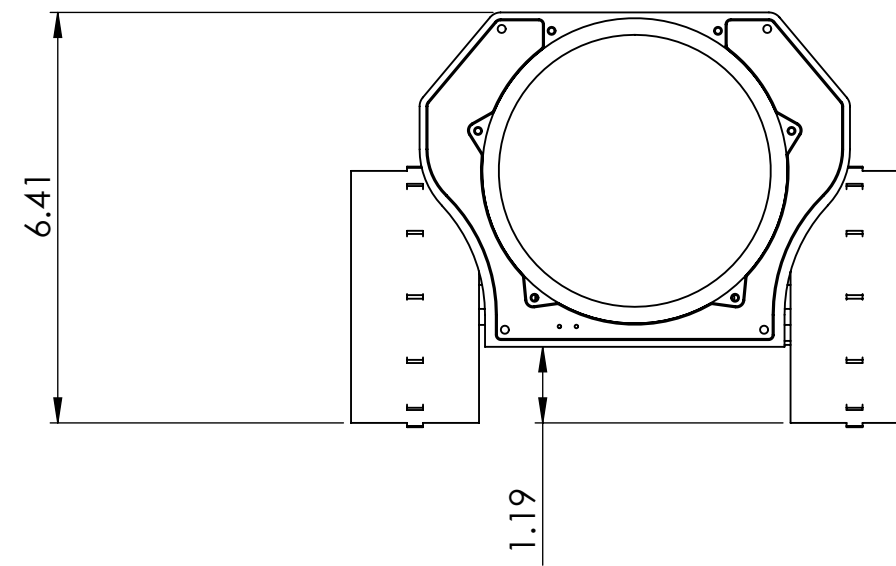

**SUPERDROID ROBOTS INC**

Ph: 919-557-9162  
Fax: 775-416-2595

**PROPRIETARY AND CONFIDENTIAL**

THE INFORMATION CONTAINED IN THIS DRAWING IS THE SOLE PROPERTY OF SUPERDROID ROBOTS INC. ANY REPRODUCTION IN PART OR AS A WHOLE WITHOUT THE WRITTEN PERMISSION OF SUPERDROID ROBOTS INC IS PROHIBITED.

UNLESS OTHERWISE SPECIFIED:  
DIMENSIONS ARE IN INCHES  
ANGULAR: 0.5 deg  
TWO PLACE DECIMAL  $\pm 0.03$   
THREE PLACE DECIMAL  $\pm 0.005$

COMMENTS:

SIZE DWG. NO.

**C** 10in Pipe Inspection Robot Assy

REV 8-2-16

SCALE: 1:3

MATERIAL:

SHEET 1 OF 1